

Checklists for oil storage tanks.

Page 1

Completing this checklist will help you decide whether you need to improve your oil storage facilities. Based on the Control of Pollution (Oil Storage) (England) Regulations 2001.

1. General requirements		✓ or ✗	Comments
1.1	Is the tank "fit for purpose" and in good condition (unlikely to leak or burst in ordinary use)?		
1.2	Is the tank situated more than 10m from a watercourse or 50m from a well or borehole? If unsure contact the Agencies.		If NO, existing and new tank must comply with the Regulations by 1 September 2003
1.3	Is the tank situated within a secondary containment system?		
1.4	Is the tank/containment system located or protected so that an impact or collision cannot damage it?		
2. Secondary containment: storage capacity		✓ or ✗	Comments
2.1	For a single tank, is the secondary containment at least 110% of the maximum storage capacity of the tank?		
2.2	For two or more tanks in one secondary containment system, is the secondary containment at least 110% of the biggest tank's maximum storage capacity or 25% of the total maximum storage capacity of all the tanks, whichever is the greatest?		
3. Secondary containment: integrity		✓ or ✗	Comments
3.1	Is the secondary containment impermeable to water and oil?		
3.2	Is the containment system intact and without openings or valves for drainage?		Ensure any cracks or other damage are carefully repaired
3.3	Are any draw-off pipes and fill pipes that pass through the containment system sealed adequately?		
4. Tank ancillary equipment		✓ or ✗	Comments
4.1	Are all valves, filters, sight gauges, vent pipes and taps within the secondary containment system?		If NO, not complying with the Regulations, section 3 (3).
4.2	If the tank has a sight gauge, is it supported properly and fitted with a valve that closes automatically when the gauge is not in use?		If NO, not complying with the Regulations, section 4 (2).
4.3	Are fill and draw-off pipes located or protected so that an impact or a collision cannot damage them?		If NO, not complying with the Regulations, section 4 (3).
4.4	And, if applicable, are materials that are liable to corrosion suitably protected?		If NO, not complying with the Regulations, section 4 (3c).
4.5	And, if above ground, supported properly?		If NO, not complying with the Regulations, section 4 (3a).
4.6	Are vent pipes, taps and valves arranged so that any oil lost will be retained within the containment system?		If NO, not complying with the Regulations, section 4 (8).
4.7	Are all taps and valves fixed to the storage tank, through which oil can be discharged to the open, fitted with locks and locked shut when not in use?		If NO, not complying with the Regulations, section 4 (8).
5. Deliveries to the tank (filling)		✓ or ✗	Comments
5.1	Is the fill pipe situated within the secondary containment system, or if not, is a drip tray of adequate capacity provided to contain any oil that may remain in the pipework after filling?		Ensure drip tray is emptied after the tank is filled, use soak away granules and dispose of as special waste.
5.2	Can the tank and vent be seen from the point where the filling operation is controlled, or if not, is the tank fitted with an automatic overfill prevention device?		
5.3	If the tank has a screw fitting or other fixed coupling, is it in good condition?		
5.4	Are fittings/couplings being used when the tank is filled?		You may need to discuss this with your oil supplier
6 Flexible draw off pipes		✓ or ✗	Comments
6.1	Is the flexible draw off pipe fitted with a tap or valve at the delivery end that closes automatically when the draw off pipe is not in use?		If the tap or valve is capable of being fixed in the open position, it should have an automatic shut-off device
6.2	Is the pipe kept within the secondary containment system when not in use or enclosed in a secure cabinet equipped with a drip tray?		
6.3	Is there a lockable valve where the pipe leaves the container, which is locked, shut when not in use?		
7. Pump set draw-off (non gravity draw off)		✓ or ✗	Comments
7.1	Is the pump set fitted with a non-return valve in the feed line to the pump?		
7.2	Is the pump set protected from unauthorised use (locked or isolated when not in use)?		
7.3	Is the pump set located or protected so that an impact or a collision cannot damage it?		

Checklists for oil storage tanks.

Diagram of a bunded oil tank.

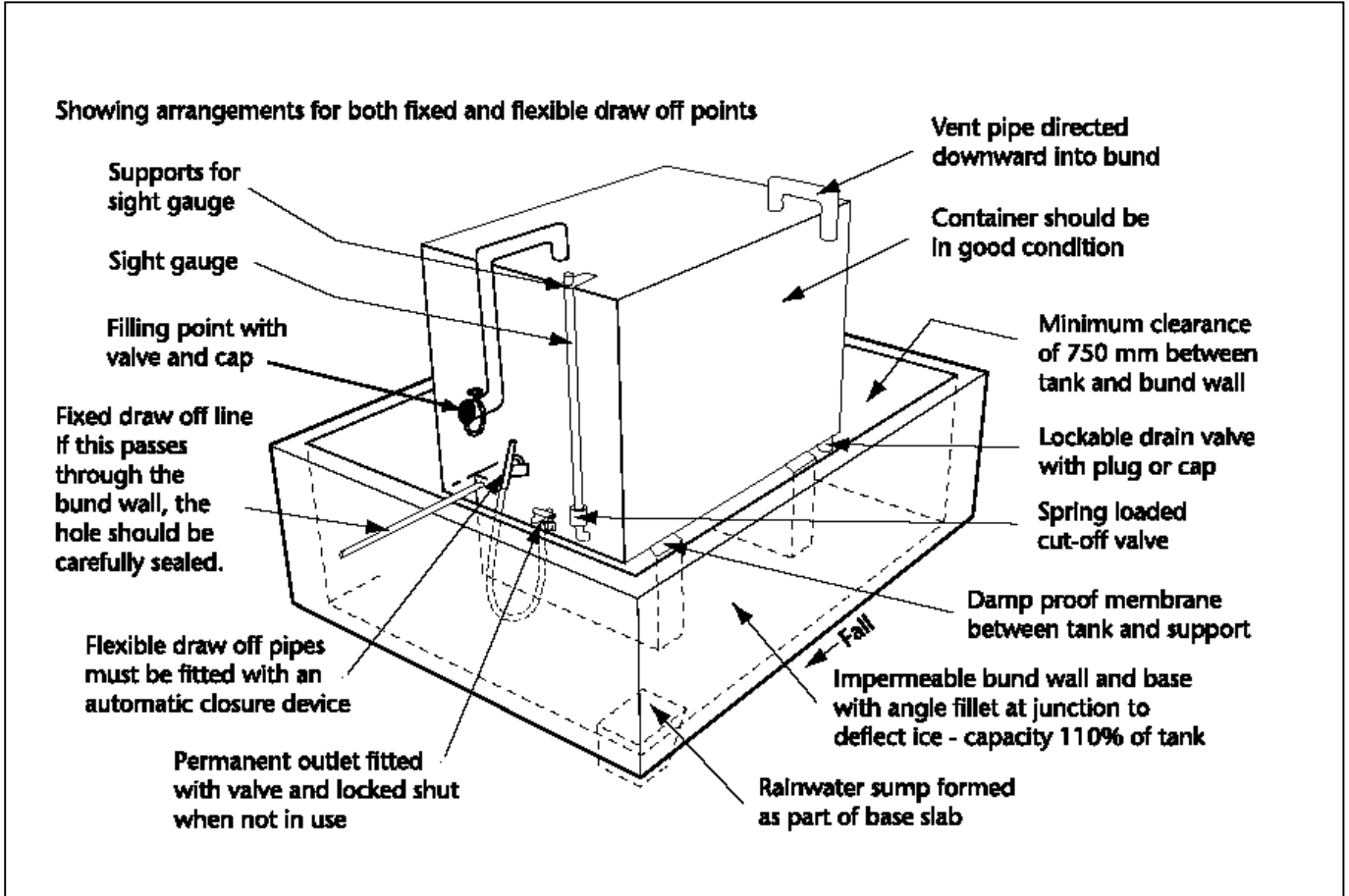

Static bowser



Mobile bowser